

3000 TSB



THE 3000TSB IS A FULLY AUTOMATIC PRESSURE SENSITIVE LABELLER SUITABLE FOR MILK & JUICE BOTTLE LABELLING

FEATURES

- Designed and manufactured to be integrated into any production line
- Applies front and back labels to 1 litre, 2 litre or 3 litre square milk bottles
- Round bottle fully wrap label application is also available as an option
- Quick changeovers with calibrated adjustment
- Optional feed screw assembly for positive product separation with quick connect / disconnect changeover (Must be selected for round bottles)
- Output rates of up to 220 products per minute
- PLC controller and operator interface with memory recall
- Twin side belts are used to position and hold the product during labelling with no contact to bottle opening
- Label placement accuracy (\pm) 1.2mm
- Safety guarding to Australian Standards

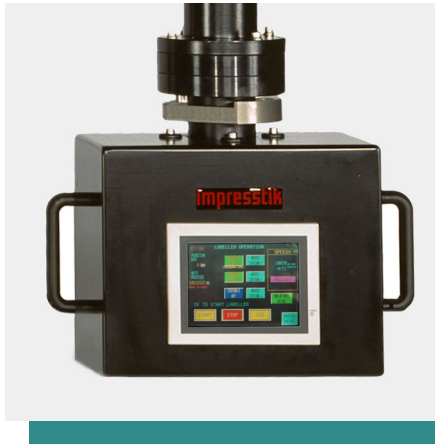

TOUCH SCREEN / HARDWARE

- The PLC is a fully integrated labelling head controller.
- Operator interface touch screen
- Able to multitask multiple labelling heads from one unit
- Memory recall of electronic set points.
- Automatic synchronising label feed / product feed
- Monochrome touch screens / colour available (optional)
- PLC operator interface can be specified (Mitsubishi standard)
- AC motors / Inverters SEW

FEED SCREW ASSEMBLY (For round bottles)

- Positive product separation
- Made to suit individual product sizes and shapes if required
- Easy connect/disconnect for quick changeover
- Colours available for product/tool identification
- AC motor / inverter SEW for conveyor and feed screw

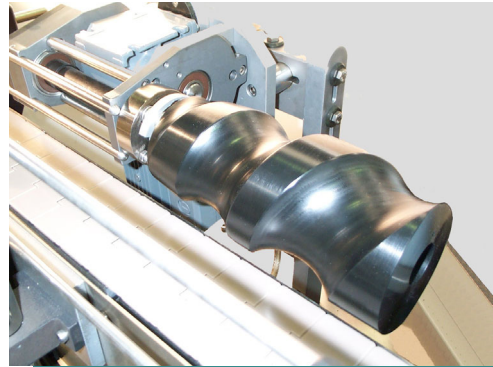

CONVEYOR MODULE STANDARD

- 3 1/4" chain x 2600m long / Special design for milk industries

LABELLING HEAD 3000TSB

- PLC Controlled
- AC Servo with positioning
- 150mm web drive (Optional 90-120-180-220)
- Label placement ($\pm 1\text{mm}$)
- Applicator support with two directional slides
- End of reel scanner
- Motorised waste rewind
- Infrared label gap scanner / capacitive optional
- Disk dia $\text{\O}350\text{mm}$ standard (Optional $\text{\O}380$)

SAFETY

All machines are designed to Australian standards. The 3000TSB is equipped with a combination of mechanical and light curtain guarding integrated into a standard safety circuit

POWER REQUIREMENT

- 240V AC Single Phase 20 amps
- 415V AC Three Phase 20 amps

Size specifications vary to suit customers requirements

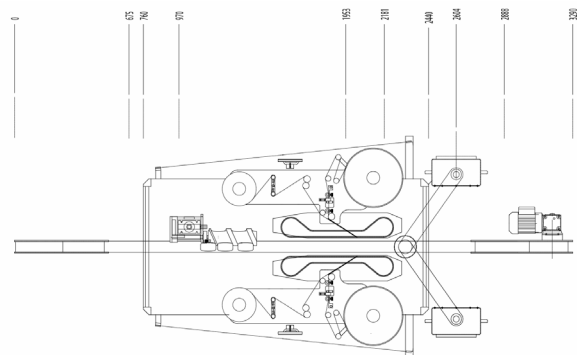
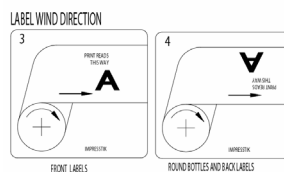

3000TSB

